



RIGID, MOLDED PLASTIC PIPE CASE

Pipe and drape hardware isn't cheap, so Drape Kings designed and built the most cost effective, economical solution for pipe transport. That's not to say pipe bags are not a viable solution – but if you want to protect the thin-wall aluminum pipe in a truck from other ATA style hard cases, loading and trucking, consider a hard-wall plastic pull along pipe case. With thousands in use worldwide, why consider anything else to protect your investment.

FEATURES

- » Exclusively designed and manufactured by Drape Kings
- » Built-in wheels and handles for easy hauling
- » Available in 8' and 10' lengths
- » Holds up to 16 uprights or 20 horizontals
- » Offers optimum protection
- » Recommended adjustable upright quantity
- » Recommended horizontal drape support count (what you can carry, not jam in)
- » Other uses include stands, display pipe and extrusions, traveler track...
- » Designed and built in the USA
- » Made of recycled polyethylene



DIMENSIONS FOR 8' MODEL

- » Empty weight (with lid): 35 lbs
- » Empty weight (hamper only): 21 lbs
- » Empty weight (lid only): 14 lbs
- » Recommended weight capacity: 300lbs

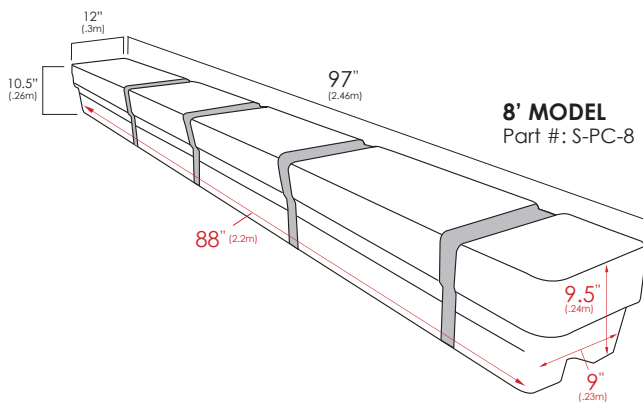

DIMENSIONS FOR 10' MODEL

- » Empty weight (with lid): 42 lbs
- » Empty weight (hamper only): 26 lbs
- » Empty weight (lid only): 16 lbs
- » Recommended weight capacity: 300lbs

